

Write your name here

Surname

Other names

**Pearson Edexcel Certificate**  
**Pearson Edexcel**  
**International GCSE**

Centre Number

--	--	--	--	--

Candidate Number

--	--	--	--	--

# Mathematics A

## Paper 4H



**Higher Tier**

Tuesday 19 January 2016 – Morning  
**Time: 2 hours**

Paper Reference  
**4MA0/4H**  
**KMA0/4H**

**You must have:**

Ruler graduated in centimetres and millimetres, protractor, compasses, pen, HB pencil, eraser, calculator. Tracing paper may be used.

Total Marks

### Instructions

- Use **black** ink or ball-point pen.
- **Fill in the boxes** at the top of this page with your name, centre number and candidate number.
- Answer **all** questions.
- Without sufficient working, correct answers may be awarded no marks.
- Answer the questions in the spaces provided  
– *there may be more space than you need.*
- **Calculators may be used.**
- You must **NOT** write anything on the formulae page.  
Anything you write on the formulae page will gain NO credit.

### Information

- The total mark for this paper is 100.
- The marks for **each** question are shown in brackets  
– *use this as a guide as to how much time to spend on each question.*

### Advice

- Read each question carefully before you start to answer it.
- Check your answers if you have time at the end.

Turn over ►

P46911A

©2016 Pearson Education Ltd.

1/1/1/



**PEARSON**

**International GCSE MATHEMATICS  
FORMULAE SHEET – HIGHER TIER**

Pythagoras' Theorem

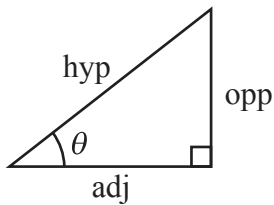
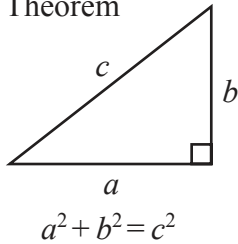

adj = hyp  $\times$  cos  $\theta$   
opp = hyp  $\times$  sin  $\theta$   
opp = adj  $\times$  tan  $\theta$

or  $\sin \theta = \frac{\text{opp}}{\text{hyp}}$

$\cos \theta = \frac{\text{adj}}{\text{hyp}}$

$\tan \theta = \frac{\text{opp}}{\text{adj}}$

Volume of cone =  $\frac{1}{3} \pi r^2 h$

Curved surface area of cone =  $\pi r l$

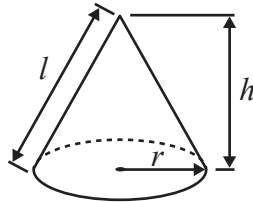

Volume of sphere =  $\frac{4}{3} \pi r^3$

Surface area of sphere =  $4 \pi r^2$

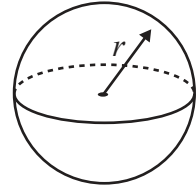

In any triangle ABC

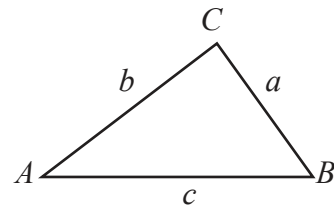

Sine rule:  $\frac{a}{\sin A} = \frac{b}{\sin B} = \frac{c}{\sin C}$

Cosine rule:  $a^2 = b^2 + c^2 - 2bc \cos A$

Area of triangle =  $\frac{1}{2} ab \sin C$

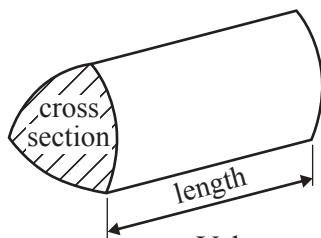

Volume of prism = area of cross section  $\times$  length

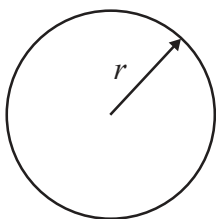

Circumference of circle =  $2 \pi r$

Area of circle =  $\pi r^2$

Area of a trapezium =  $\frac{1}{2}(a + b)h$

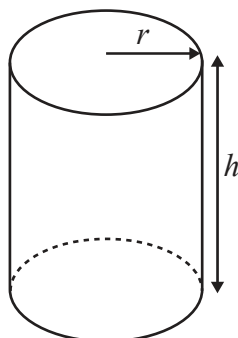
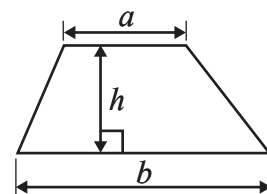

Volume of cylinder =  $\pi r^2 h$

Curved surface area of cylinder =  $2 \pi r h$

The Quadratic Equation

The solutions of  $ax^2 + bx + c = 0$ , where  $a \neq 0$ , are given by

$$x = \frac{-b \pm \sqrt{b^2 - 4ac}}{2a}$$



DO NOT WRITE IN THIS AREA

DO NOT WRITE IN THIS AREA

DO NOT WRITE IN THIS AREA

Answer ALL TWENTY FIVE questions.

Write your answers in the spaces provided.

You must write down all the stages in your working.

1 (a) Work out the value of  $\frac{\sqrt{4.6}}{8.1 - 3.7}$

Give your answer as a decimal.

Write down all the figures on your calculator display.

..... (2)

(b) Write your answer to part (a) correct to 3 significant figures.

..... (1)

(Total for Question 1 is 3 marks)

2  $D = 3e^2 + 4e$

Work out the value of  $D$  when  $e = -5$

$D =$  .....

(Total for Question 2 is 2 marks)



3 Here are 8 cards.

There is a number on each of six cards.  
Two cards are blank.



Uzma wants the mean of the numbers on the 8 cards to be 4  
She wants the range of the numbers on the 8 cards to be 9

Find the numbers that she should write on the two blank cards.

..... and .....

**(Total for Question 3 is 3 marks)**

4 Karen has a spinner.

When the spinner is spun once, the probability that it will land on yellow is  $\frac{2}{5}$   
Karen spins the spinner 30 times.

Work out an estimate for the number of times the spinner lands on yellow.

.....

**(Total for Question 4 is 2 marks)**



DO NOT WRITE IN THIS AREA

DO NOT WRITE IN THIS AREA

DO NOT WRITE IN THIS AREA

5

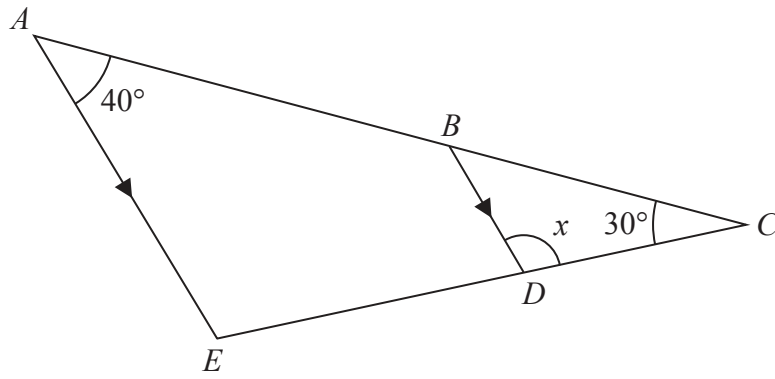

Diagram **NOT** accurately drawn

$ABC$  and  $EDC$  are straight lines.  
 $AE$  is parallel to  $BD$ .  
 Angle  $EAC = 40^\circ$   
 Angle  $ACE = 30^\circ$

Work out the size of angle  $x$ .  
 Give reasons for your answer.

$x = \dots\dots\dots^\circ$

**(Total for Question 5 is 3 marks)**

6  $B$  is the point with coordinates  $(1, 4)$   
 $C$  is the point with coordinates  $(6, 9)$

Find the coordinates of the midpoint of  $BC$ .

(....., .....) )

**(Total for Question 6 is 2 marks)**



7 A clothes shop has a sale.

In the sale, normal prices are reduced by 12%  
The normal price of a shirt is £30

(a) Work out the sale price of the shirt.

£ .....  
(3)

The price of a coat is reduced by £9 in the sale.

(b) Work out the normal price of the coat.

£ .....  
(3)

(Total for Question 7 is 6 marks)



DO NOT WRITE IN THIS AREA

DO NOT WRITE IN THIS AREA

DO NOT WRITE IN THIS AREA

8 A box contains toy cars.  
Each car is red or blue or black or silver.

Emily takes at random a car from the box.  
The table shows the probabilities that Emily takes a red car or a blue car or a black car.

Colour of car	Probability
red	0.20
blue	0.05
black	0.15
silver	

(a) Work out the probability that Emily takes a silver car.

.....  
(2)

Emily puts the car back into the box.  
There are 6 blue cars in the box.

(b) Work out the total number of cars in the box.

.....  
(2)

**(Total for Question 8 is 4 marks)**



9 (a) Expand  $x(x + 2)$

.....  
(1)

(b) Solve the inequality  $4x - 7 > 3$

.....  
(2)

(c) Solve  $\frac{3 - 5m}{4} = 8$

Show clear algebraic working.

$m =$  .....  
(3)

**(Total for Question 9 is 6 marks)**

10 The lengths of the sides of a triangle are in the ratios  $2 : 6 : 7$   
The length of the longest side of the triangle is 24.5 cm.

Work out the perimeter of the triangle.

..... cm

**(Total for Question 10 is 3 marks)**





DO NOT WRITE IN THIS AREA

DO NOT WRITE IN THIS AREA

DO NOT WRITE IN THIS AREA

11 Solve the simultaneous equations

$$5x + y = 17$$

$$x + y = 3$$

Show clear algebraic working.

$$x = \dots\dots\dots$$

$$y = \dots\dots\dots$$

**(Total for Question 11 is 3 marks)**

12 Find an equation of the line that is parallel to the line  $y = 4 - 2x$  and passes through the point (3, 7)

**(Total for Question 12 is 3 marks)**



13 Here is a regular 10-sided polygon.

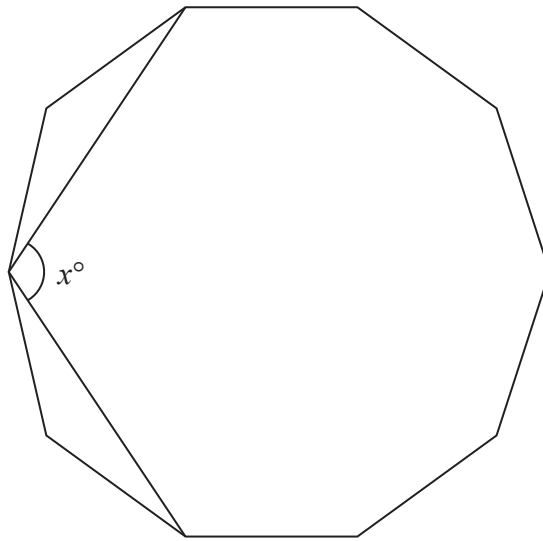

Diagram **NOT** accurately drawn

Work out the value of  $x$ .  
Show your working clearly.

$x = \dots\dots\dots$

(Total for Question 13 is 4 marks)

DO NOT WRITE IN THIS AREA

DO NOT WRITE IN THIS AREA

DO NOT WRITE IN THIS AREA



14

Diagram NOT accurately drawn

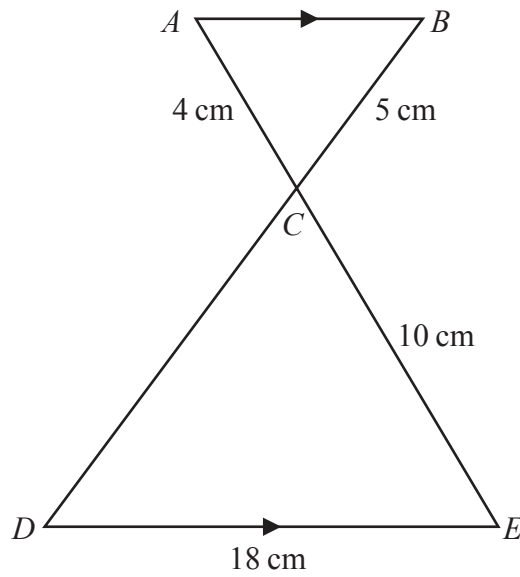

$ACE$  and  $BCD$  are straight lines.  
 $AB$  is parallel to  $DE$ .

(a) Calculate the length of  $CD$ .

.....cm  
 (2)

(b) Calculate the length of  $AB$ .

.....cm  
 (2)

The area of triangle  $ABC = T \text{ cm}^2$

(c) Find the area of triangle  $CDE$  in terms of  $T$ .

..... $\text{cm}^2$   
 (1)

(Total for Question 14 is 5 marks)

DO NOT WRITE IN THIS AREA

DO NOT WRITE IN THIS AREA

DO NOT WRITE IN THIS AREA



15 The cumulative frequency table shows information about the heights of 60 men.

Height ( $h$ cm)	Cumulative frequency
$140 < h \leq 150$	10
$140 < h \leq 160$	35
$140 < h \leq 170$	52
$140 < h \leq 180$	58
$140 < h \leq 190$	60

(a) On the grid, draw a cumulative frequency graph for the table.

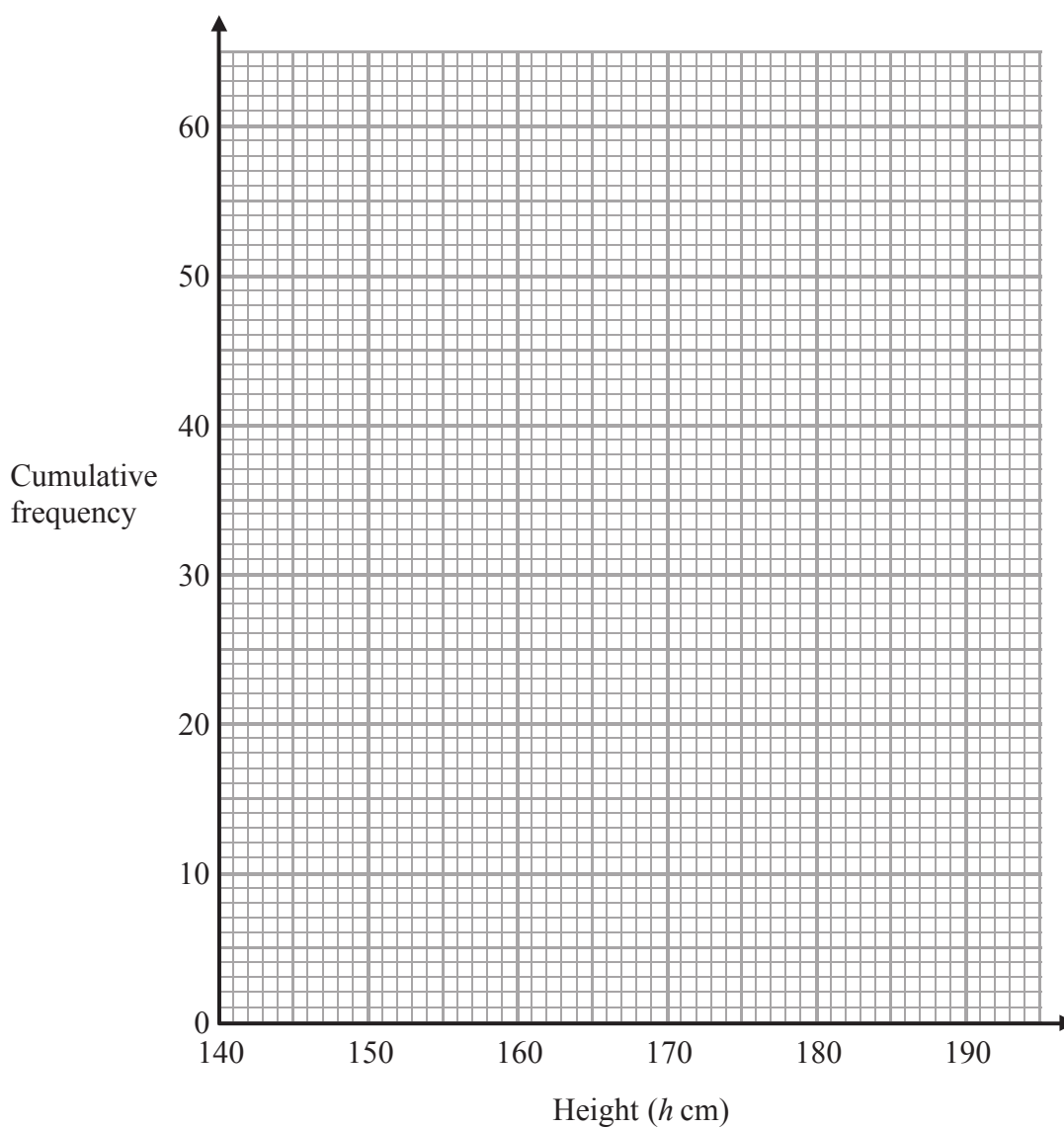

(2)



DO NOT WRITE IN THIS AREA

DO NOT WRITE IN THIS AREA

DO NOT WRITE IN THIS AREA

(b) Use your graph to find an estimate for the median height of the 60 men.

.....cm

(2)

(c) Use your graph to find an estimate for the number of the men who are taller than 174 cm.

.....

(2)

**(Total for Question 15 is 6 marks)**



DO NOT WRITE IN THIS AREA

DO NOT WRITE IN THIS AREA

DO NOT WRITE IN THIS AREA

16 The curve  $C$  has equation  $y = 3x^2 - 12x + 8$

(a) Find  $\frac{dy}{dx}$

$$\frac{dy}{dx} = \dots\dots\dots (2)$$

(b) Find the coordinates of the point on  $C$  where the gradient of the curve is 18

$$(\dots\dots\dots, \dots\dots\dots) (3)$$

(Total for Question 16 is 5 marks)



DO NOT WRITE IN THIS AREA

DO NOT WRITE IN THIS AREA

DO NOT WRITE IN THIS AREA

17 (a) Simplify  $\left(\frac{8e^6}{f^{12}}\right)^{\frac{1}{3}}$

.....  
(2)

(b) Factorise fully  $2y^2 - 72$

.....  
(2)

(c) Simplify  $\frac{2p^2 - p - 15}{p^2 - 3p}$

.....  
(3)

(Total for Question 17 is 7 marks)



18  $y$  is directly proportional to  $\sqrt{x}$   
When  $x = 49$ ,  $y = 4$

(a) Find a formula for  $y$  in terms of  $x$ .

.....  
(3)

(b) Calculate the value of  $x$  when  $y = 12$

$x =$  .....  
(2)

**(Total for Question 18 is 5 marks)**

DO NOT WRITE IN THIS AREA

DO NOT WRITE IN THIS AREA

DO NOT WRITE IN THIS AREA





19

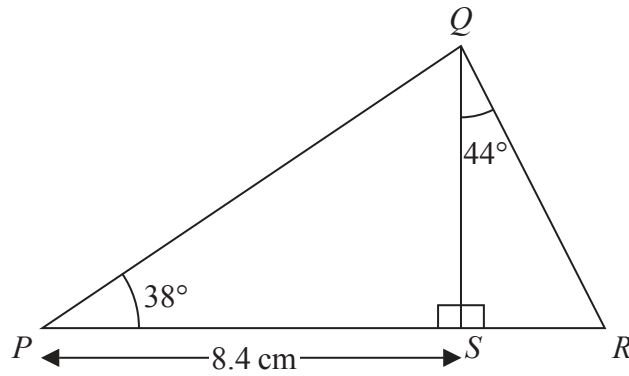

Diagram **NOT**  
accurately drawn

$PSR$  is a straight line.

Angle  $PSQ = 90^\circ$

$PS = 8.4\text{ cm}$

Angle  $QPS = 38^\circ$

Angle  $SQR = 44^\circ$

Work out the length of  $QR$ .

Give your answer correct to 3 significant figures.

.....cm

(Total for Question 19 is 4 marks)

DO NOT WRITE IN THIS AREA

DO NOT WRITE IN THIS AREA

DO NOT WRITE IN THIS AREA



Diagram **NOT** accurately drawn

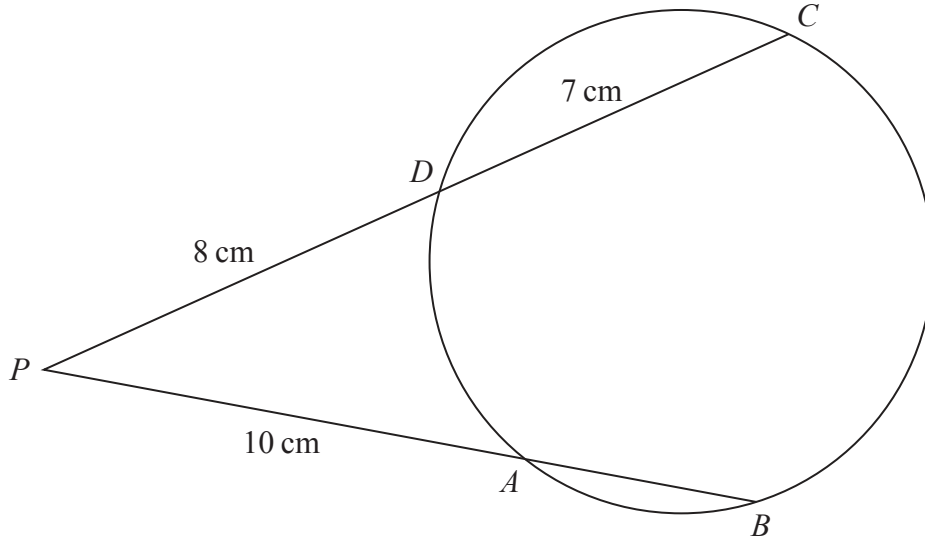

DO NOT WRITE IN THIS AREA

DO NOT WRITE IN THIS AREA

DO NOT WRITE IN THIS AREA

$A, B, C$  and  $D$  are points on a circle.  
 $PAB$  and  $PDC$  are straight lines.  
 $PA = 10$  cm,  $PD = 8$  cm and  $DC = 7$  cm.  
 Calculate the length of  $AB$ .

..... cm

(Total for Question 20 is 3 marks)



21

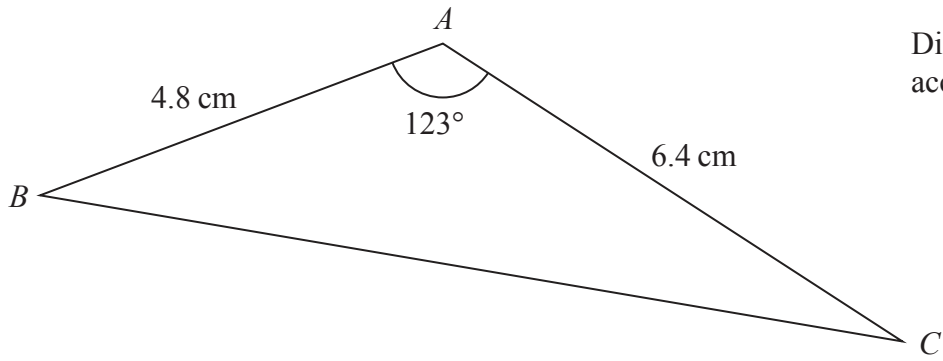

Diagram **NOT** accurately drawn

Calculate the length of  $BC$ .  
Give your answer correct to 3 significant figures.

.....cm

(Total for Question 21 is 3 marks)

DO NOT WRITE IN THIS AREA



22 Solve the equation  $\frac{6}{x-2} - \frac{6}{x+1} = 1$

Show clear algebraic working.

DO NOT WRITE IN THIS AREA

DO NOT WRITE IN THIS AREA

DO NOT WRITE IN THIS AREA

(Total for Question 22 is 5 marks)



DO NOT WRITE IN THIS AREA

DO NOT WRITE IN THIS AREA

DO NOT WRITE IN THIS AREA

23 The diagram shows a solid cylinder.

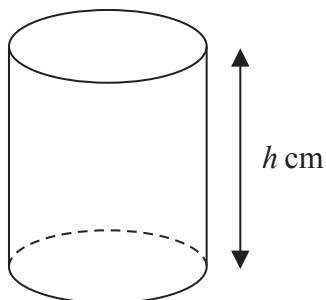

Diagram **NOT** accurately drawn

The cylinder has radius  $4\sqrt{3}$  cm and height  $h$  cm.  
The total surface area of the cylinder is  $56\pi\sqrt{6}$  cm<sup>2</sup>

Find the exact value of  $h$ .  
Give your answer in the form  $a\sqrt{2} + b\sqrt{3}$ , where  $a$  and  $b$  are integers.  
Show your working clearly.

$h = \dots\dots\dots$

(Total for Question 23 is 5 marks)



24 The diagram shows sector  $OAB$  of a circle, centre  $O$ .

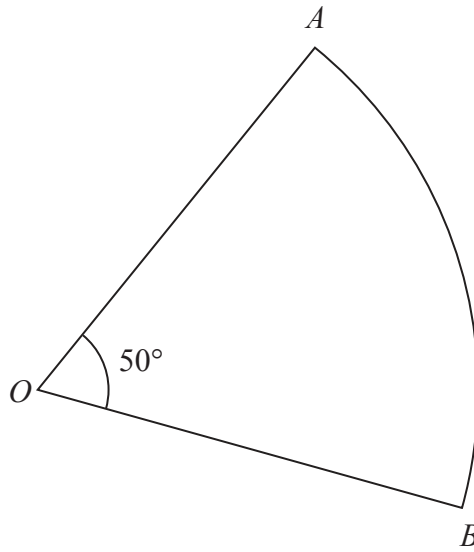

Diagram **NOT** accurately drawn

Angle  $AOB = 50^\circ$

Sector  $OAB$  has area  $20\pi \text{ cm}^2$

Calculate the perimeter of sector  $OAB$ .

Give your answer correct to 3 significant figures.

.....cm

(Total for Question 24 is 5 marks)

DO NOT WRITE IN THIS AREA

DO NOT WRITE IN THIS AREA

DO NOT WRITE IN THIS AREA



DO NOT WRITE IN THIS AREA

DO NOT WRITE IN THIS AREA

DO NOT WRITE IN THIS AREA

25  $y = 16 \times 10^{8k}$  where  $k$  is an integer.

Find an expression, in terms of  $k$ , for  $y^{\frac{5}{4}}$   
Give your answer in standard form.

.....  
(Total for Question 25 is 3 marks)

---

**TOTAL FOR PAPER IS 100 MARKS**



DO NOT WRITE IN THIS AREA

DO NOT WRITE IN THIS AREA

DO NOT WRITE IN THIS AREA

**BLANK PAGE**

**Do NOT write on this page.**

